

REV. 更改	DESCRIPTION 说明	ENG. 修改人	APPROVE 审核

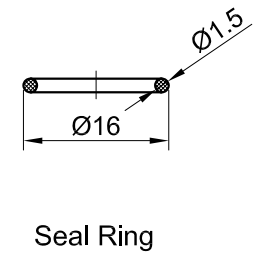
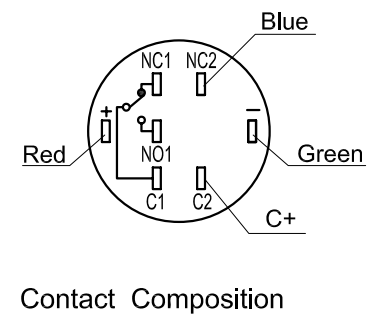
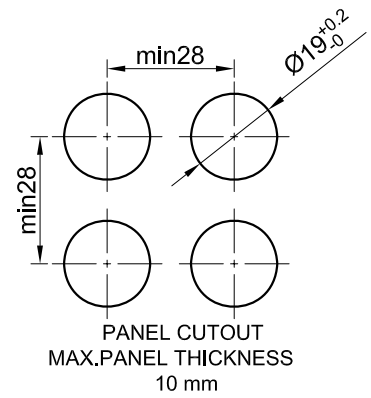
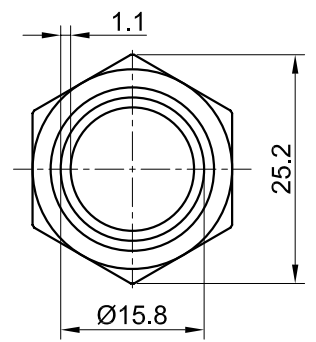
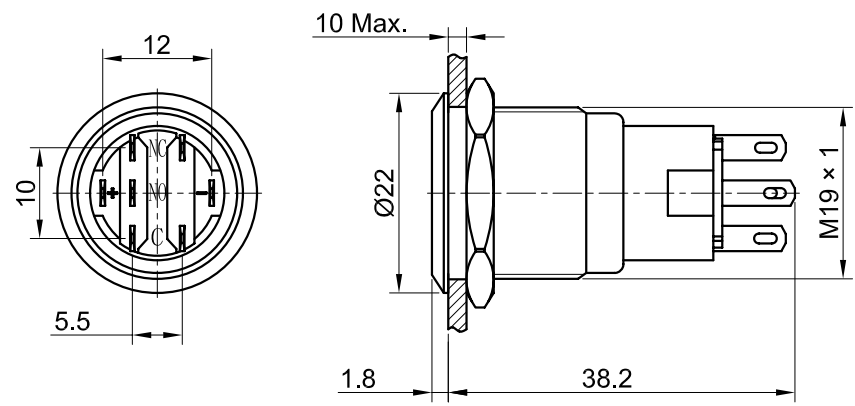

**SPECIFICATIONS:**

- 1.Max.Switch Rating: Ith:5A Ui: 250VAC.
- 2.Rating: 0.5A 220VAC.
- 3.Electrical Life: ≥50,000cycles.
- 4.Contact Resistance: ≤50mΩ.
- 5.Insulation Resistance: ≥1,000MΩ.
- 6.Dielectric Strength: 2,000VAC.
- 7.Operating Temperature: -25℃ ~ +55℃ (No Freezing).
- 8.IP Class: IP67.
- 9.Operating Force: About 2N.
- 10.Contact Composition:1NO1NC.
- 11.Torque: 0.8Nm max.applied to nut.
- 12.Ring illuminated.
- 13.LED Color:Red Green Blue.
- 14.LED Voltage: 6V.
- 15.Operation mode:Latching type.

**MATERIALS:**

- 1.Contact: Silver alloy.
- 2.Button: Stainless Steel.
- 3.Body: Stainless Steel.
- 4.Base: PBT.

Part Number: PM192- 11ZE / 42RGB / 12V / S

DIMENSIONS		TOLERANCE		SCALE		UNIT		DR.	
0.00 TO 30.00mm		±0.20mm		比例 1.2 / 1		mm		制图 HMJ 2017/02/17	
30.01 TO 80.00mm		±0.25mm		名称 Anti-vandal metal push button		图号		SIZE 图纸 A4	
80.01 TO 150.00mm		±0.30mm							
150.01 ↑		±0.40mm		MATERIAL		DWG NO. 档案名称		SHEET 1 / 1	
								REV. 更改 1	