



SanDisk[®] microSD[™], microSDHC[™] and microSDXC[™]

OEM Product Manual

Revision 3.1

Document No. 80-36-03335

November 2013

SanDisk Corporation

Corporate Headquarters • 951 SanDisk Drive. • Milpitas, CA 95035

Phone (408) 801-1000 • Fax (408) 801-8657

www.sandisk.com

Products, samples and prototypes are subject to update and change for technological and manufacturing purposes.

SanDisk Corporation general policy does not recommend the use of its products in life support applications wherein a failure or malfunction of the product may directly threaten life or injury. Without limitation to the foregoing, SanDisk shall not be liable for any loss, injury or damage caused by use of its products in any of the following applications:

- Special applications such as military related equipment, nuclear reactor control, and aerospace
- Control devices for automotive vehicles, train, ship and traffic equipment
- Safety system for disaster prevention and crime prevention
- Medical-related equipment including medical measurement device

Accordingly, in any use of SanDisk products in life support systems or other applications where failure could cause damage, injury or loss of life, the products should only be incorporated in systems designed with appropriate redundancy, fault tolerant or back-up features. Per SanDisk Terms and Conditions of Sale, the user of SanDisk products in life support or other such applications assumes all risk of such use and agrees to indemnify, defend and hold harmless SanDisk Corporation and its affiliates against all damages.

Security safeguards, by their nature, are capable of circumvention. SanDisk cannot, and does not, guarantee that data will not be accessed by unauthorized persons, and SanDisk disclaims any warranties to that effect to the fullest extent permitted by law.

This document and related material is for information use only and is subject to change without prior notice. SanDisk Corporation assumes no responsibility for any errors that may appear in this document or related material, nor for any damages or claims resulting from the furnishing, performance or use of this document or related material. SanDisk Corporation explicitly disclaims any express and implied warranties and indemnities of any kind that may or could be associated with this document and related material, and any user of this document or related material agrees to such disclaimer as a precondition to receipt and usage hereof. EACH USER OF THIS DOCUMENT EXPRESSLY WAIVES ALL GUARANTIES AND WARRANTIES OF ANY KIND ASSOCIATED WITH THIS DOCUMENT AND/OR RELATED MATERIALS, WHETHER EXPRESS OR IMPLIED, INCLUDING WITHOUT LIMITATION, ANY IMPLIED WARRANTY OF MERCHANTABILITY OR FITNESS FOR A PARTICULAR PURPOSE OR INFRINGEMENT, TOGETHER WITH ANY LIABILITY OF SANDISK CORPORATION AND ITS AFFILIATES UNDER ANY CONTRACT, NEGLIGENCE, STRICT LIABILITY OR OTHER LEGAL OR EQUITABLE THEORY FOR LOSS OF USE, REVENUE, OR PROFIT OR OTHER INCIDENTAL, PUNITIVE, INDIRECT, SPECIAL OR CONSEQUENTIAL DAMAGES, INCLUDING WITHOUT LIMITATION PHYSICAL INJURY OR DEATH, PROPERTY DAMAGE, LOST DATA, OR COSTS OF PROCUREMENT OF SUBSTITUTE GOODS, TECHNOLOGY OR SERVICES.

No part of this document may be reproduced, transmitted, transcribed, stored in a retrievable manner or translated into any language or computer language, in any form or by any means, electronic, mechanical, magnetic, optical, chemical, manual or otherwise, without the prior written consent of an officer of SanDisk Corporation.

All parts of the SanDisk documentation are protected by copyright law and all rights are reserved.

SanDisk and the SanDisk logo are trademarks of SanDisk Corporation, registered in the United States and other countries. SD, microSD, microSDHC and microSDXC marks and logos are trademarks of SD-3C, LLC. All other brand names mentioned herein are for identification purposes only and may be the trademarks of their respective holder(s).

© 2013 SanDisk Corporation. All rights reserved.
Document No. 80-36-03335 Rev 3.1

Revision History

Date	Revision	Description
July 2008	1.0	First Revision
June 2010	2.0	Added 32 GB Replaced SD 2.0 with SD 3.0 ACMD41 to ready after power up updated Updated marking, section 5 Updated Tables 7, 9, and 11 to remove < 1G references Updated Figure 1 – SD card block diagram
March 2011	2.1	Added speed class to Ordering Information Table
April 2011	2.2	Added 64GB and updated SDA 3.0 to SD3.UHS-I 50
October 2011	2.3	Added SDSDQAC SKUs to Ordering Information. Updated Figure 7 to add High Performance figure.
November 2011	2.4	Added Ordering Information.
January 2012	2.5	Reference to SDA corrections. Added SDSDQAD SKUs to Ordering Information
July 2012	2.6	Marking info updated with alternate laser marking guide and Premier microSD product marking info
July 2013	3.0	Removed High Performance line (SDSDQAC)
November 2013	3.1	Added SDSDQAE SKUs Removed SDSDQ SKUs Removed random IOPs performance from ordering information

Table of Contents

1	Introduction.....	1
1.1	General Description.....	1
1.2	Features.....	2
1.3	Scope.....	2
1.4	SD Card Standard.....	2
1.5	Functional Description.....	3
1.5.1	Technology Independence.....	3
1.5.2	Defect and Error Management.....	3
1.5.3	Content Protection.....	3
1.5.4	Wear Leveling.....	3
1.5.5	Automatic Sleep Mode.....	3
1.5.6	Hot Insertion.....	4
1.6	microSD Card Products in SD Bus Mode.....	4
1.7	SPI Mode.....	6
2	Product Specifications.....	7
2.1	microSD Card Product Family.....	7
2.1.1	Typical Card Power Requirements.....	7
2.1.2	System Performance.....	8
2.1.3	Reliability and Durability.....	9
2.1.4	Physical Specifications.....	9
3	Interface Description.....	10
3.1	Pins and Registers.....	10
3.2	Bus Topology.....	11
3.2.1	SD Bus.....	11
3.2.2	SPI Bus.....	11
3.3	Hot Insertion and Power Protection.....	11
3.4	Electrical Interface.....	11
3.4.1	Power Up.....	11
3.4.2	Bus Operating Conditions.....	12
3.4.3	Bus Timing.....	12
3.5	microSD Card Product Family Registers.....	12
3.5.1	Operation Conditions Register.....	12
3.5.2	Card Identification Register.....	12
3.5.3	Card Specific Data Register.....	13
3.5.4	Card Status Register.....	15
3.5.5	SD Status Register.....	16
3.5.6	Relative Card Address Register.....	16
3.5.7	SD Card Configuration Register.....	16
3.5.8	microSD Card Product Family Registers in SPI Mode.....	16
3.5.9	Data Interchange Format and Card Sizes.....	16
4	microSD Card Protocol Description.....	17
4.1	General Description.....	17
4.2	SD Bus Protocol.....	17
4.3	Functional Description.....	17

4.3.1	Card Identification Mode.....	17
4.3.2	Data Transfer Mode.....	17
4.3.3	Clock Control.....	18
4.3.4	Cyclic Redundancy Codes.....	18
4.3.5	Error Conditions.....	18
4.3.6	Commands.....	18
4.3.7	Card State Transition.....	18
4.3.8	Timing Diagrams and Values.....	18
4.3.9	Speed Class Specification.....	18
4.3.10	Erase Timeout Calculation.....	18
5	Marking.....	19
6	Ordering Information.....	21

1 INTRODUCTION

1.1 General Description

The SanDisk® microSD™, microSDHC™ (High Capacity) and microSDXC™ (Extended Capacity) cards are flash based removable non-volatile memory devices specifically designed to meet the security, capacity, performance and environmental requirements inherent in next generation mobile phones and consumer electronic devices. The SanDisk microSD card is based on the SD™ Card specification.

The SanDisk microSD card includes a content protection system that complies with the security of the Secure Digital Music Initiative (SDMI) standard and has a higher memory capacity. In the SanDisk microSD card, card content is protected from unauthorized use by mutual authentication and a cipher algorithm. Unsecured access to the user's own content is also available.

microSD cards are based on a 8-pin interface designed to operate in a maximum operating frequency of 208 MHz. The interface for microSD card products allows for easy integration into any design, regardless of which type of microprocessor is used. In addition to the interface, microSD card products offer an alternate communication-protocol based on the SPI standard.

SanDisk microSD card Product Family provides up to 64 gigabytes (GB)¹ of memory using flash memory chips, which were designed especially for use in mass storage applications. In addition to the mass storage-specific flash memory chip, cards in the microSD Card Product Family includes an on-board intelligent controller which manages interface protocols; security algorithms for content protection; data storage and retrieval, as well as Error Correction Code (ECC) algorithms; defect handling; power management; wear leveling, and clock control.

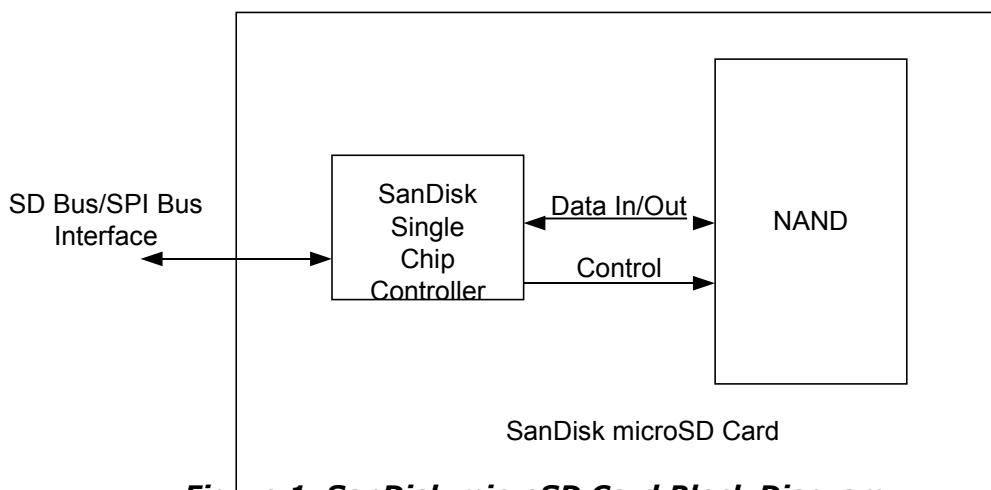

Figure 1: SanDisk microSD Card Block Diagram

1.2 Features

General features of cards in the SanDisk microSD Memory Card Product Family include:

- Up to 64 GB¹ of data storage
- SD - protocol compatible
- Supports SPI Mode
- Targeted for portable and stationary applications for secured (content protected) and unsecured data storage
- Voltage range of 2.7 to 3.6V
- Variable clock rate 0-25 MHz (standard), 0-50 MHz (high performance), 0-208 MHz (Ultra High Speed)
- Up to 104 MB/sec* data transfer rate (using four parallel data lines)
- Memory field error correction
- Content protection mechanism that complies with highest security of SDMI standard
- Password protection
- Built-in write protection features (permanent and temporary)
- Supports card detection (insertion and removal)
- Application-specific commands

1.3 Scope

This document describes key features and specifications of the SanDisk microSD cards as well as the information required to interface these products to a host system. Chapter 2 describes the physical and mechanical properties of cards in the SanDisk microSD Card Product Family, Chapter 3 contains the pins and register overview, and Chapter 4 gives a general overview of the SD protocol. Information about SPI Protocol can be referenced in Section 7 of the SDA Physical Layer Specification, Version 3.01.

1.4 SD Card Standard

SanDisk microSD memory cards are fully compatible with the SDA Physical Layer Specification, Version 3.01. This specification is available from the SD Card Association (SDA).

SD Card Association
2400 Camino Ramon, Suite 375
San Ramon, CA 94583 USA
Telephone: +1 (925) 275-6615
Fax: +1 (925) 886-4870
E-mail: office@sdcard.org
Web site: www.sdcard.org

1.5 Functional Description

The family of SanDisk microSD cards contains a high-level, intelligent subsystem as shown in Figure 1. This intelligent (microprocessor) subsystem provides many capabilities not found in other types of memory cards. These capabilities include:

- Host independence from details of erasing and programming flash memory
- Sophisticated system for managing defects (analogous to systems found in magnetic disk drives)
- Sophisticated system for error recovery including a powerful ECC
- Power management for low power operation

1.5.1 Technology Independence

The 512-byte sector size of a card in the SanDisk microSD Card Product Family is the same as that in an IDE magnetic disk drive. To write or read a sector (or multiple sectors), the host software simply issues a read or write command to the card. The command contains the address and number of sectors to write or read. The host software then waits for the command to complete.

The host software does not get involved in the details of how the flash memory is erased, programmed or read. This is extremely important because flash devices are expected to get increasingly complex in the future. Because cards in the SanDisk microSD Card Product Family use an intelligent on-board controller, host system software will not need to be updated as new flash memory evolves. In other words, systems that support the microSD Card Product Family today will be able to access future SanDisk cards built with new flash technology without having to update or change host software.

1.5.2 Defect and Error Management

The SanDisk microSD Card Product Family contains a sophisticated defect and error management system. This system is analogous to the systems found in magnetic disk drives and in many cases offers enhancements. If necessary, SanDisk microSD Card Product Family will rewrite data from a defective sector to a good sector. This is completely transparent to the host and does not consume any user data space.. In the extremely rare case that a read error does occur, SanDisk microSD Memory Card Product Family has innovative algorithms to recover the data. These defect and error management systems, coupled with the solid state construction, give SanDisk microSD Card Product Family enormous reliability.

1.5.3 Content Protection

A detailed description of the content protection mechanism and related security SD commands can be found in the SD Security Specification from the SDA. All SD security-related commands in the SanDisk microSD Card Product Family operate in the data transfer mode.

1.5.4 Wear Leveling

Wear leveling is an intrinsic part of the erase pooling functionality of cards in the SanDisk microSD Card Product Family using NAND memory.

1.5.5 Automatic Sleep Mode

A unique feature of cards in the SanDisk microSD Card Product Family is automatic entrance and exit from sleep mode. Upon completion of an operation, cards enter

sleep mode to conserve power if no further commands are received in less than 5 milliseconds (ms). The host does not have to take any action for this to occur. However, in order to achieve the lowest sleep current, the host needs to shut down its clock to the card. In most systems, cards are in sleep mode except when accessed by the host, thus conserving power.

When the host is ready to access a card in sleep mode, any command issued to it will cause it to exit sleep, and respond.

1.5.6 Hot Insertion

Support for hot insertion will be required on the host but will be supported through the connector. Connector manufacturers will provide connectors that have power pins long enough to be powered before contact is made with the other pins.

1.6 microSD Card Products in SD Bus Mode

The following sections provide valuable information on cards in the SanDisk microSD Card Product Family in SD Bus mode.

Cards in the SanDisk microSD Card Product Family are fully compliant with the SDA Physical Layer Specification, Version 3.01. Card Specific Data (CSD) Register structures are compliant with CSD Structure 1.0 and 2.0.

This section covers Negotiating Operating Conditions, Card Acquisition and Identification, Card Status, Memory Array Partitioning, Read/Write Operations, Data Transfer Rate, Data Protection in Flash Cards, Write Protection, Copy Bit, and CSD Register.

Additional practical card detection methods can be found in application notes pertaining to the SDA Physical Layer Specification, Version 3.01.

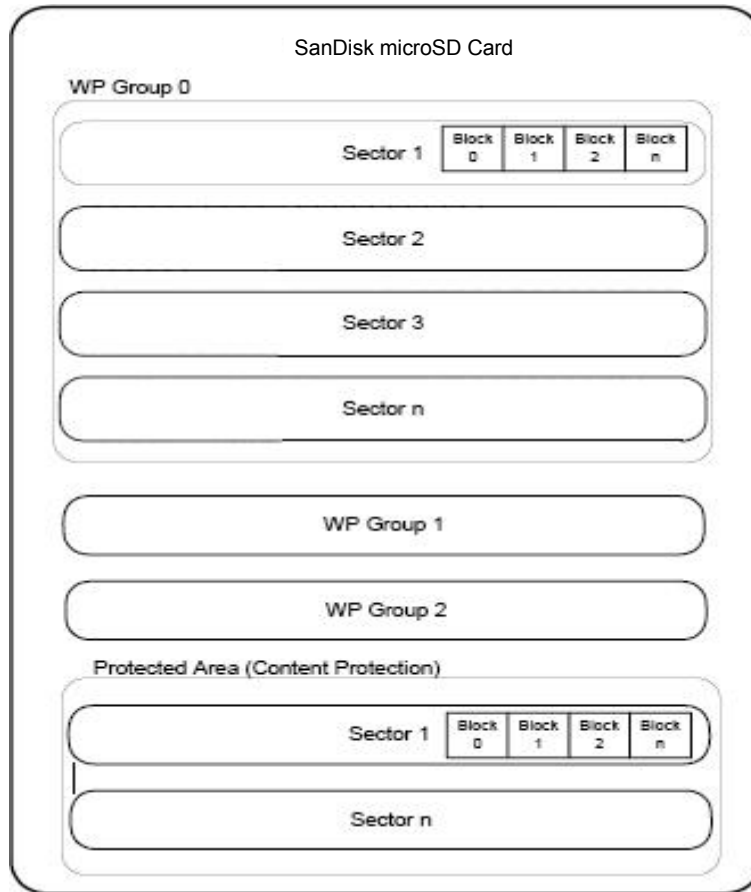

Figure 2: Memory Array Partitioning

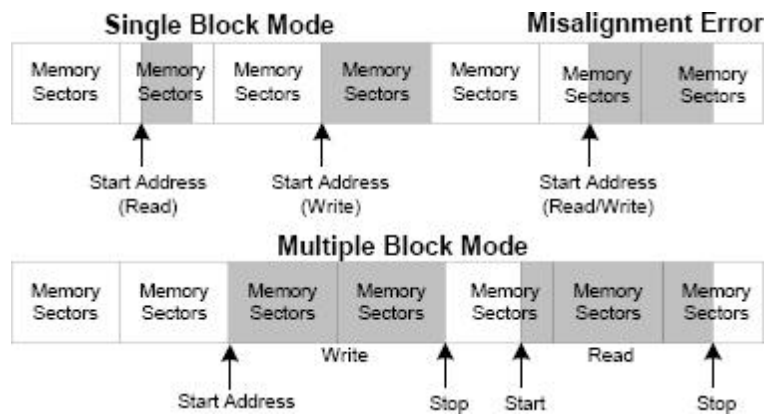

Figure 3: Data Transfer Formats

Table 1 contains descriptions for each transfer mode.

Table 1: Mode Descriptions

Mode	Description
Single Block	<p>In this mode the host reads or writes one data block in a pre-specified length. The data block transmission is protected with 16-bit CRC that is generated by the sending unit and checked by the receiving unit.</p> <p>The block length for read operations is limited by the device sector size (512 bytes) but can be as small as a single byte. Misalignment is not allowed. Every data block must be contained in a single physical sector.</p> <p>The block length for write operations must be identical to the sector size and the start address aligned to a sector boundary.</p>
Multiple Block	<p>This mode is similar to the single block mode, except for the host can read/write multiple data blocks (all have the same length) that are stored or retrieved from contiguous memory addresses starting at the address specified in the command. The operation is terminated with a stop transmission command.</p> <p>Misalignment and block length restrictions apply to multiple blocks and are identical to the single block read/write operations.</p>

1.7 SPI Mode

The SPI Mode is a secondary communication protocol for cards in the SanDisk microSD Card Product Family. This mode is a subset of the SD Protocol, designed to communicate with an SPI channel, commonly found in Motorola and other vendors' microcontrollers. Detailed information about SPI Mode can be found in Section 7 or the SDA Physical Layer Specification, Version 3.01.

2 PRODUCT SPECIFICATIONS

2.1 microSD Card Product Family

This section provides product specifications for the SanDisk microSD Card Product Family. For more details about the environmental, reliability and durability specifications, refer the SDA Physical Layer Specification, Version 3.01 and microSD card addendum v3.0.

Mode	Maximum Value	Typical Value @ 25C
Standard Mode (25 MHz)		
Sleep		350 uA
Read	100 mA	
Write	100 mA	
Standard Mode – for microSDXC card -XPC bit on (25 MHz)		
Host selected XPC bit in ACMD41		
Sleep		350 uA
Read	150 mA	
Write	150 mA	
High Performance Mode (50 MHz)		
Sleep		350 uA
Read	200 mA	
Write	200 mA	
UHS-I SDR50/104 Mode – (104/208 MHz)		
Sleep		350 uA
Read	400 mA	
Write	400 mA	
UHS-I DDR50 Mode – (50 MHz)		
Sleep		350 uA
Read	400 mA	
Write	400 mA	

2.1.1 Typical Card Power Requirements

The values stated in Table 2 represent the SanDisk microSD Card power requirements.

Table 2: SanDisk microSD Card Power Requirements

Note: Current consumption is measured by averaging over one (1) second. Refer to Section 6.6.3 of the SDA Physical Layer Specification, Version 3.01 for more information

2.1.2 System Performance

This section provides the system performance specifications for the SanDisk microSD Card Product Family. All performance values in Table 3 were measured under the following conditions:

- Voltage range 2.7 to 3.6V
- Temperature -25°C to 85°C
- Independent of card clock frequency

Table 3: System Performance

Timing	Maximum Value
Block Read Access Time	100 ms
Block Write Access Time	250 ms for SDHC, 500ms for SDXC
ACMD41 to ready after power-up	1s

2.1.3 Reliability and Durability

For SanDisk microSD environmental, reliability and durability specifications, refer to SDA Physical Layer Specification, Version 3.01 and microSD Card Addendum v3.0.

2.1.4 Physical Specifications

Figure 4 and Figure 5 provide the physical dimensions of the SanDisk microSD Card. For detail dimensions and tolerances refer to SDA microSD Card Addendum, Mechanical Specification for microSD Memory Card.

Note: Dimensions are in mm.

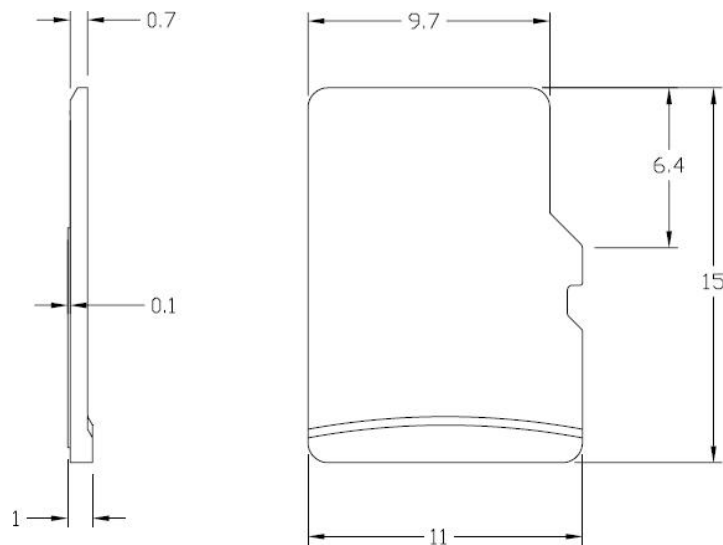

Figure 4: microSD Card Top View and Side View

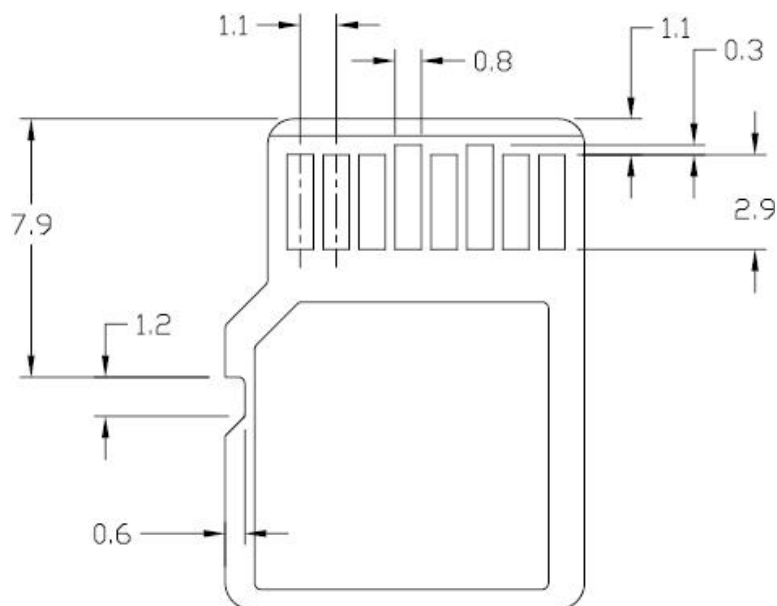

Figure 5: microSD Card Bottom View

3 INTERFACE DESCRIPTION

3.1 Pins and Registers

The SanDisk microSD™ Card Product Family has exposed contacts on one side. The host uses a dedicated connector to connect to microSD cards.

In Table 4, pin assignments for the SanDisk microSD Card are described for SD Bus Mode and SPI Bus Mode

Note: Pin assignments are provided by the SDA Physical Layer Specification, Version 3.01 and associated addendums (microSD). For more details, refer to Section 3.7 of the SDA Physical Layer Specification, Version 3.01

Table 4: SD Bus Mode Pin Assignment

Pin No.	SD Mode			SPI mode		
	Name	Type ¹	Description	Name	Type ¹	Description
1	DAT2 ^{2,5}	I/O/PP	Data Line [bit 2]	RSV	-	Reserved
2	CD/DAT3 ²	I/O/PP ³	Card Detect/Data Line [bit 3]	CS	I ³	Chip select (active low)
3	CMD	PP	Command/Response	DataIn	I	Data In
4	V _{DD}	S	Supply Voltage	V _{DD}	S	Supply Voltage
5	CLK	I	Clock	SCLK	I	Clock
6	V _{SS}	S	Supply voltage ground	V _{SS}	S	Supply voltage ground
7	DAT0	I/O/PP	Data Line [bit 1]	DataOUT	O/PP	Data Out
8	DAT1 ^{2,4}	I/O/PP	Data Line [bit 2]	RSV ⁴	-	Reserved

- Notes:
1. Type Key: S=power supply; I=input; O=output using push-pull drivers; PP=I/O using push-pull drivers.
 2. The extended DAT lines (DAT1-DAT3) are input on power up. They start to operate as DAT lines after the SET_BUS_WIDTH command. It is the responsibility of the host designer to connect external pull-up resistors to all data lines even if only DAT0 is to be used. If not, there may be unexpected high current consumption due to the floating inputs of DAT1 & DAT2 (if they are not used).
 3. At power up this line has a 50KOhm pull-up enabled in the card. This resistor serves two functions: Card Detection and Mode Selection. For Mode Selection, the host can drive the line high or let it be pulled high to select SD mode. If the host wants to select SPI mode, it should drive the line low. For Card Detection, the host detects that the line is pulled high. The user should disconnect this pull-up with SET_CLR_CARD_DETECT (ACMD42) command during regular data transfer.
 4. DAT1 line may be used as Interrupt Output (from the Card) in SDIO mode during all the times that it is not in use for data transfer operations.
 5. DAT2 line may be used as Read Wait signal in SDIO mode.

Each card has a set of information registers. Register descriptions and SDA references are provided in Section 5.0 of the SDA Physical Layer Specification, Version 3.01.

Table 5: microSD Card Product Family Register Overview

Register Abbreviation	Width (in bits)	Register Name
CID	128	Card identification number
RCA	16	Relative card address
CSD	128	Card specific data
SCR	64	SD configuration register
OCR	32	Operation condition register
SSR	512	SD status register
CSR	32	Card status register

3.2 Bus Topology

The family of SanDisk microSD products supports two communication protocols: SD and SPI. For more details, refer to Section 3.5 of the SDA Physical Layer Specification, Version 3.01. Section 6 of the specification contains a bus circuitry diagram for reference.

3.2.1 SD Bus

For more details, refer to Section 3.5.1 of the SDA Physical Layer Specification, Version 3.01.

3.2.2 SPI Bus

For more details, refer to Section 3.5.2 of the SDA Physical Layer Specification, Version 3.01.

3.3 Hot Insertion and Power Protection

Refer to Section 6.1 and Section 6.2 of the SDA Physical Layer Specification, Version 3.01.

3.4 Electrical Interface

The power scheme of SanDisk microSD products is handled locally in each card and in the bus master. Refer to Section 6.4 of the SDA Physical Layer Specification, Version 3.01.

3.4.1 Power Up

Power must be applied to the VDD pin before any I/O pin is set to logic HIGH. In other words, CMD, CLK, and DAT0-3 must be at zero (0) volts when power is applied to the VDD pin. For more information, refer to Section 6.4.1 of the SDA Physical Layer Specification, Version 3.01.

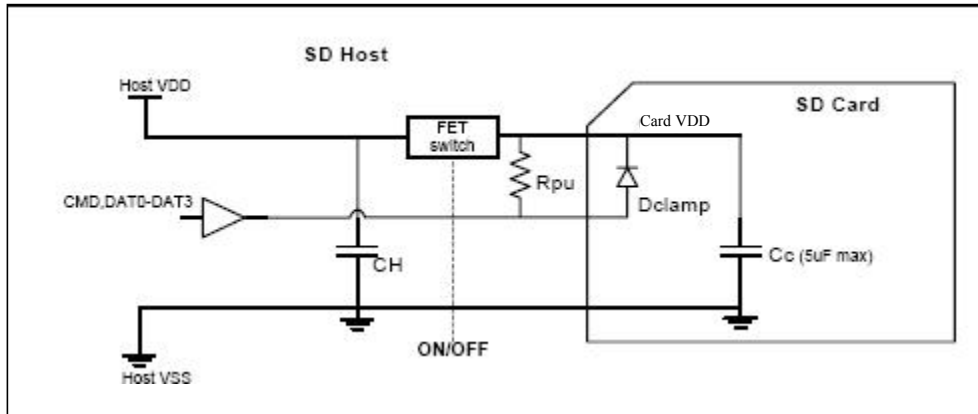

Figure 6: Recommended Power Control Scheme

The recommended power control scheme for SanDisk microSD cards is illustrated in Figure 6. Most card connectors have a card detect switch that signals the SD host when the card is inserted. After the host is aware of the card insertion, it turns on the FET switch to apply power to card's VDD pin.

Once the card is inserted and all card pins are making contact, there should be a delay before the FET switch is turned on.

Note: Because there are clamping diodes on the CMD, CLK, and DAT0-3 pins, it is crucial to ensure that CLK, CMD, and DAT0-3 are at zero (0) volts during the delay and before the FET switch is turned on. If any I/O pin, (CMD, CLK, or DAT0-3) goes above zero volts during the delay and before power reaches the card VDD pin, it will forward bias the clamping diodes and can cause the card to go into an unknown state. It is the host's responsibility to make sure power gets to VDD before CMD, CLK, or DAT0-3 go above zero volts.

3.4.2 Bus Operating Conditions

SPI Mode bus operating conditions are identical to SD Card Bus Mode operating conditions. For details, see Section 6.6 of the SDA Physical Layer Specification, Version 3.01.

3.4.3 Bus Timing

See SDA Physical Layer Specification, Version 3.01.

3.5 microSD Card Product Family Registers

There is a set of eight registers within the card interface. However, the DSR Register is optional and is not used in the SanDisk microSD Card Product Family. For specific information about all registers, refer to Section 5 of the SDA Physical Layer Specification, Version 3.01.

3.5.1 Operation Conditions Register

The Operation Conditions Register (OCR) stores a card's VDD voltage profile. Refer to Section 5.1 of the SDA Physical Layer Specification, Version 3.01 for more information.

3.5.2 Card Identification Register

The Card Identification (CID) Register is 16 bytes long and contains the unique card identification number. It is programmed during card manufacturing and cannot be changed by card hosts. See Table 8.

Table 6: CID Register Definitions

Name	Type	Width	CID Value	Comments
Manufacturer ID (MID)	Binary	8	0x03	Manufacturer IDs are controlled and assigned by the SD-3C, LLC
OEM/Application ID (OID)	ASCII	16	SD ASCII Code 0x53, 0x44	Identifies the card OEM and/or the card contents. The OID is controlled and assigned by the SD-3C, LLC
Product Name (PNM)	ASCII	40	SU64G SU32G SU16G SU08G SU04G SU02G SU01G	Five-character ASCII string
Product Revision (PRV)	BCD	8	Product Revision xx	See Section 5.2 in the SDA Physical Layer Specification, Version 3.01.
Serial Number (PSN)	Binary	32	Product serial number	32-bit unsigned integer
Reserved	-	4	-	-
Manufacturer Date Code (MDT)	BCD	12	Manufacture date (for example, April 2001=0x014)	Manufacturing date–yym (offset from 2000)
CRC7 Checksum (CRC)	Binary	7	CRC7	Calculated
Not used, always 1	-	1	-	-

3.5.3 Card Specific Data Register

The Card Specific Data (CSD) Register configuration information is required to access card data. The CSD defines the data format, error correction type, maximum data access time, etc. The field structures of the CSD Register vary depending on the physical specifications and card capacity. The CSD_STRUCTURE field in the CSD Register indicates which structure version is used. Table 9 shows the version number as it relates to the CSD structure. Refer to Section 5.3.1 of the SDA Physical Layer Specification, Version 3.01 for more information.

Table 7: CSD Register Structure

CSD_Structure	CSD Structure Version	Valid for SD Card Physical Specification / Card Capacity
0	CSD Version 1.0	Version 1.01 to 1.10 Version 2.00/Standard Capacity
1	CSD Version 2.0	Version 2.00/High Capacity and Extended Capacity
2-3	Reserved	-

Table 8 provides an overview of the CSD Register. More field-specific information can be found in Section 5.3.2 of the SDA Physical Layer Specification, Version 3.01.

Field	Typical CSD Value	Description
CSD_STRUCTURE	1.0	CSD Structure
-	-	Reserved
TAAC	1.5 msec	Data read access-time-1
NSAC	0	Data read access-time-2 in CLK cycles (NSAC*100)
TRANS_SPEED	Standard Mode 25 MHz High Performance Mode 50MHz Ultra High Speed Mode-I 104MHz	Maximum data transfer rate
CCC	All (inc. WP, lock/unlock)	Card command classes
READ_BL_LEN	2G = 0xA Up to 1G – 0x9	Maximum read data block length
READ_BL_PARTIAL	Yes	Partial blocks for read allowed
WRITE_BLK_MISALIGN	No	Write block misalignment
READ_BLK_MISALIGN	No	Read block misalignment
DSR_IMP	No	DSR implemented
-	-	Reserved
C_SIZE 1 GB 2 GB	Secured 0xF22 0xF24	Device size
VDD_R_CURR_MIN	100 mA	Maximum read current @V _{DD} min
VDD_R_CURR_MAX	80 mA	Maximum read current @V _{DD} max
VDD_W_CURR_MIN	100 mA	Maximum write current @V _{DD} min
VDD_W_CURR_MAX	80 mA	Maximum write current @V _{DD} max
C_SIZE_MULT	2G=2048 1G-1024	Device size multiplier
ERASE_BLK_EN	Yes	Erase single block enable
SECTOR_SIZE	31 blocks	Erase sector size
WP_GRP_SIZE	127 sectors	Write protect group size
WP_GRP_ENABLE	Yes	Write protect group enable
Reserved	-	Reserved for MMC compatibility
R2W_FACTOR	X16	Write speed factor
WRITE_BL_LEN	0x9	Maximum write data block length
WRITE_BL_PARTIAL	No	Partial blocks for write allowed
-	-	Reserved
FILE_FORMAT_GRP	0	File format group
COPY	Has been copied	Copy flag (OTP)
PERM_WRITE_PROTECT	Not protected	Permanent write protection
TMP_WRITE_PROTECT	Not protected	Temporary write protection
FILE_FORMAT	HD w/partition	File format
Reserved	-	Reserved
CRC	CRC7	CRC
-	-	Not used, always "1"

Table 8: CSD Register (CSD Version 1.0)

Refer to Section 5.3.3, Table 5-16 of the SDA Physical Layer Specification, Version 3.01 for more detailed information.

Table 9: CSD Register (CSD Version 2.0)

Field	Typical CSD Value	Description
CSD_STRUCTURE	2.0	CSD Structure
-	-	Reserved
TAAC	1.5 msec	Data read access-time
NSAC	0	Data read access-time-2 in CLK cycles (NSAC*100)
TRANS_SPEED	Standard Mode 25 MHz High Performance Mode 50MHz Ultra High Speed Mode 104MHz	Maximum data transfer rate
CCC	All (inc. WP, lock/unlock)	Card command classes
READ_BLK_LEN	9	Maximum read data block length
READ_BLK_PARTIAL	Yes	Partial blocks for read allowed
WRITE_BLK_MISALIGN	No	Write block misalignment
READ_BLK_MISALIGN	No	Read block misalignment
DSR_IMP	No	DSR implemented
-	0	Reserved
C_SIZE	See SDA Physical Layer Specification	Device size
-	0	Reserved
ERASE_BLK_EN	1	Erase single block enable
SECTOR_SIZE	64 blocks	Erase sector size
WP_GRP_SIZE	000000b	Write protect group size
WP_GRP_ENABLE	No	Write protect group enable
Reserved	-	Reserved for MMC compatibility
R2W_FACTOR	X4	Write speed factor
WRITE_BLK_LEN		Maximum write data block length
WRITE_BLK_PARTIAL	No	Partial blocks for write allowed
-	-	Reserved
FILE_FORMAT_GRP	0	File format group
COPY	Has been copied	Copy flag (OTP)
PERM_WRITE_PROTECT	Not protected	Permanent write protection
TMP_WRITE_PROTECT	Not protected	Temporary write protection
FILE_FORMAT	HD w/partition	File format
Reserved	-	Reserved
CRC	CRC7	CRC
-	-	Not used, always "1"

3.5.4 Card Status Register

The Card Status Register (CSR) transmits the card's status information (which may be stored in a local status register) to the host. The CSR is defined in Section 4.10.1 in the SDA Physical Layer Specification, Version 3.01.

3.5.5 SD Status Register

The SD Status Register (SSR) contains status bits that are related to the microSD Card proprietary features and may be used for future applications. The SD Status structure is described in Section 4.10.2 in the SDA Physical Layer Specification, Version 3.01.

3.5.6 Relative Card Address Register

The 16-bit Relative Card Address (RCA) Register carries the card address published by the card during the card identification. Refer to Section 5.4 in the SDA Physical Layer Specification, Version 3.01 for more information.

3.5.7 SD Card Configuration Register

The SD Card Configuration Register (SCR) is in addition to the CSD Register. The SCR provides information about special features in the SanDisk SD Card products. For more information, refer to Section 5.6 in the SDA Physical Layer Specification, Version 3.01.

3.5.8 microSD Card Product Family Registers in SPI Mode

All card registers are accessible in SPI Mode. Their format is identical to the format in the SD Bus Mode; however a few fields are irrelevant in SPI Mode. In SPI Mode, the Card Status Register also has a different, shorter format. Refer to Section 7.4 in the SDA Physical Layer Specification, Version 3.01 for more details.

3.5.9 Data Interchange Format and Card Sizes

In general, a file system provides structure for data in SanDisk microSD Card products. The SD Card File System Specification, published by the SDA, describes the file format system that is implemented in the SanDisk microSD Card products. In general, each card is divided into two separate DOS-formatted partitions as follows:

- User Area—used for secured and non-secured data storage and can be accessed by the user with regular read/write commands.
- Security Protected Area—used by content protection applications to save security related data and can be accessed by the host using the secured read/write command after doing authentication as defined in the SD Security Specification. The security protected area size is defined by SanDisk as approximately one percent of the total size of the card.

Table 10: Minimum User Area DOS Image Parameters

Capacity ¹	Total LBAs ²	No. of Partition System Area Sectors ²	Total Partition Sectors ²	User Data Sectors ²	User Data Bytes ²
64 GB	125,000,704	66304	124,967,936	124,934,400	63,864,569,856
32GB	62,333,952	16384	62,325,760	62,309,376	31,902,400,512
16 GB	31,116,288	8192	31,108,096	31,099,904	15,923,150,848
8 GB	15,523,840	8192	15,515,648	15,507,456	7,939,817,472
4 GB	7,744,512	8192	7,736,320	7,728,128	3,956,801,536
2 GB	3,862,528	505	3,858,489	3,857,984	1,975,287,808
1 GB	1,930,240	505	1,929,177	1,928,672	987,480,064

¹ 1 (GB) = 1billion bytes. Some capacity not available for data storage.

² Total LBAs, Number of Partition System Area Sectors, Total Partition Sectors, User Data Sectors and User Data Bytes are minimum values. Actual values may vary depending on flash technology used.

4 MICROSD CARD PROTOCOL DESCRIPTION

4.1 General Description

SD™ Protocol information for cards in the SanDisk microSD™ Card Product Family is contained in this chapter; information includes SD bus protocol, card identification, and a functional description.

4.2 SD Bus Protocol

Communication over the SD bus is based on command and data-bit streams initiated by a start bit and terminated by a stop bit. See Section 3.6.1 of the SDA Physical Layer Specification, Version 3.01 for details.

4.3 Functional Description

In the SanDisk microSD Card Product Family, the host controls all communication between itself and the cards. This section provides a general overview of the card identification and data transfer modes; commands; card dependencies; various card operation modes and restrictions for controlling the clock signal. For SD Card commands, together with corresponding responses, state transitions, error conditions, and timings refer to Section 4 of the SDA Physical Layer Specification, Version 3.01.

4.3.1 Card Identification Mode

In Card Identification Mode, the host resets all cards, validates operation voltage range, identifies and requests cards to publish a relative card address. For more information see Section 4.2 in the SDA Physical Layer Specification, Version 3.01.

4.3.2 Data Transfer Mode

Functionality of the Data Transfer Mode can be found in Section 4.3 of the SDA Physical Layer Specification, Version 3.01. This section includes information about data read and write, erase, write-protect management, card lock/unlock operations, application-specific commands, switch function command, high-speed mode, command system, and the Send Interface Condition command (CMD8). CMD8 is part of identification mode and command functional differences in microSD cards.

4.3.3 Clock Control

The host can use the bus clock signal in SanDisk microSD cards to switch them to energy saving mode or to control data flow on the bus. See Section 4.4 of the SDA Physical Layer Specification, Version 3.01.

Cyclic Redundancy Codes

The Cyclic Redundancy Check (CRC) protects against transmission errors that may occur on the bus in SanDisk microSD Card Product Family cards. Detailed information and examples for CRC7 and CRC16 are provided in Section 4.5 of the SDA Physical Layer Specification, Version 3.01.

4.3.4 Error Conditions

See Section 4.6 of the SDA Physical Layer Specification, Version 3.01.

4.3.5 Commands

See Section 4.7 of the SDA Physical Layer Specification, Version 3.01 for detailed information about card commands in the SanDisk microSD Card Product Family.

4.3.6 Card State Transition

In microSD cards, the state transition is dependent on the received command. The transition is defined in Section 4.8 of the SDA Physical Layer Specification, Version 3.01 along with responses sent on the command line.

4.3.7 Timing Diagrams and Values

See Section 4.12 of the SDA Physical Layer Specification, Version 3.01.

4.3.8 Speed Class Specification

SDA speed class specification classifies card minimum write performance by speed class number and offers the method to test performance. For more information, refer to Section 4.13 of the SDA Physical Layer Specification, Version 3.01.

4.3.9 Erase Timeout Calculation

See Section 4.14 of the SDA Physical Layer Specification, Version 3.01.

5 MARKING

microSD™ cards have a laser marking indicating details on the manufacture of the card.

Field 1: CC = Capacity Code, Made in XXXXX = Country of Origin
(China or Taiwan)

Field 2: YYDDDDXXXXL###

YY is year of manufacture, 10=2010

DDD is Day of manufacturer, 001 - 365

X, L, and # are SanDisk internal markings

Field 2 (alternate marking): YWWDMTLLLXXX

Y is year of manufacture, 2=2012

WW is work week of manufacture

D, M, T, LLL, XXX are SanDisk internal markings

Note: Dimensions are in mm.

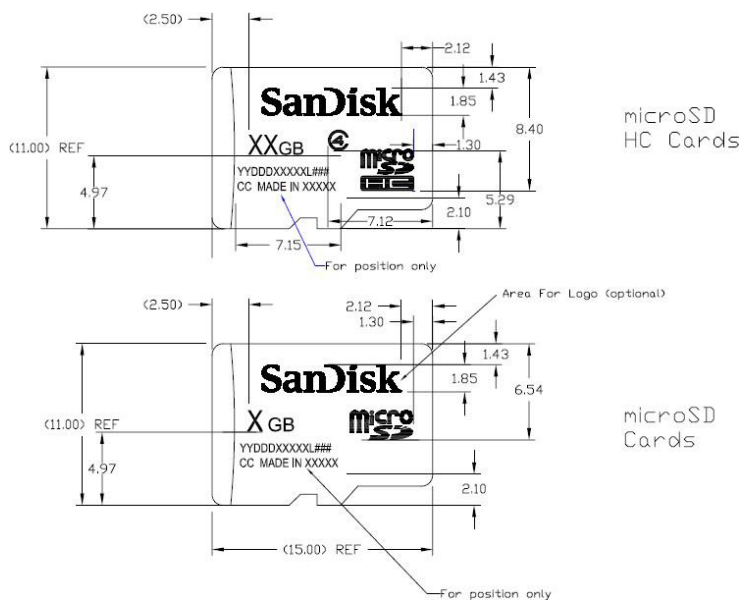

UHS-1-Cards¶

¶

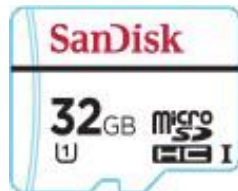
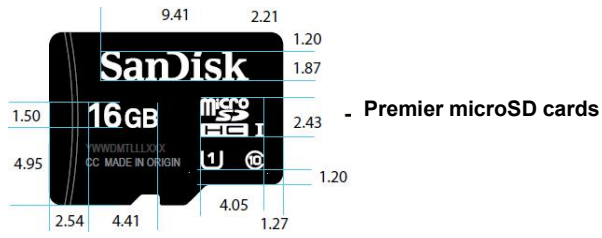

Superior microSD cards

**Figure 7: Marking Specs for
microSD, microSDHC, microSDXC, UHS-I Cards,**

6 ORDERING INFORMATION

To order SanDisk products directly from SanDisk, please contact your local sales office.

Part Number	Capacity ²	Interface	Speed Class ¹
SDSDQAB-004G	4GB	UHS-I 50	Sequential Write: 5MB/s Sequential Read: 20MB/s SC4
SDSDQAB-008G	8GB		
SDSDQAB-016G	16GB		
SDSDQAB-032G	32GB		
SDSDQAB-064G	64GB		
SDSDQAD-008G	8GB	UHS-I 50	Sequential Write: 10MB/s Sequential Read: 40MB/s U1/SC10
SDSDQAD-016G	16GB		
SDSDQAD-032G	32GB		
SDSDQAD-064G	64GB		
SDSDQAE-032G	32GB	UHS-I 104	Sequential Write: 50MB/s Sequential Read: 80MB/s U1/SC10
SDSDQAE-064G	64GB		

1. Based on SanDisk internal testing; performance may be lower depending upon host device. 1 megabyte (MB) = 1 million bytes.

2. 1 gigabyte (GB) = 1 billion bytes. Some capacity not available for data storage.